



MIXER & COOLING BLENDER SERIES

Professional Manufacturer

MIXER & COOLING BLENDER

Salvage Oriented for the Nonpareil Globe
Multiform Implements for the Noble
Garbage.....

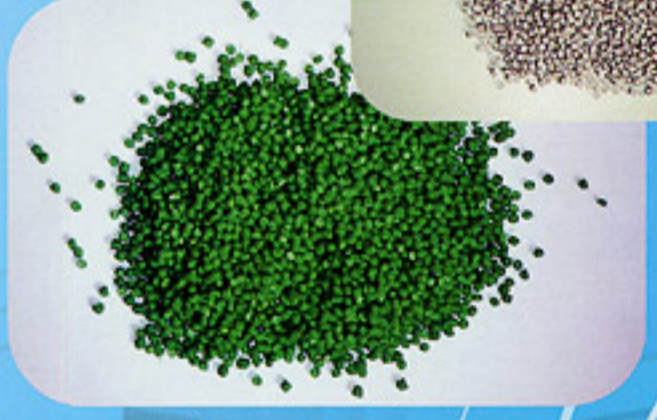
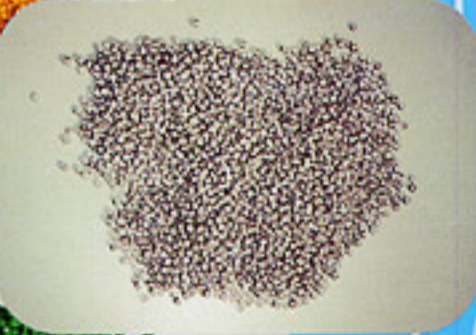
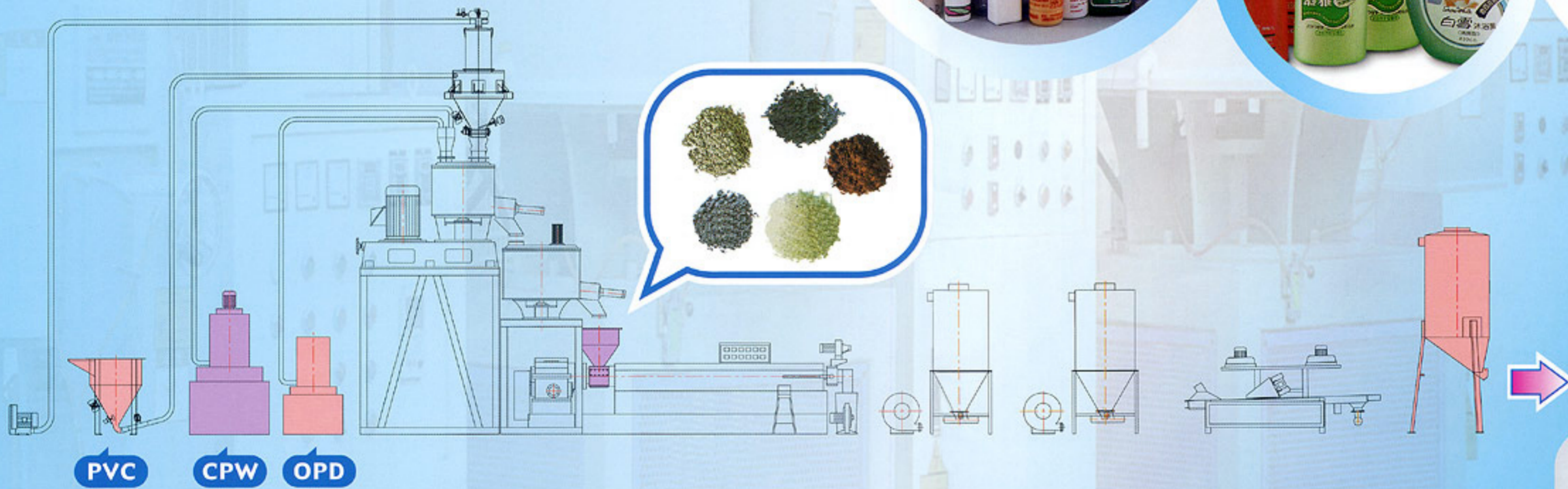

HIGH-SPEED MIXER & VERTICAL COOLING BLENDER

高速熱混合機 & 立式冷卻攪拌機

- Internal surfaces in contact with the material are made of stainless steel.
本機內部與原料接觸面都是不銹鋼材質。
- The cover is equipped with safety device, motor will stop immediately when cover is opened.
本機的桶蓋都具有安全裝置, 只要桶蓋開啓, 馬達立即停止運轉。

CE

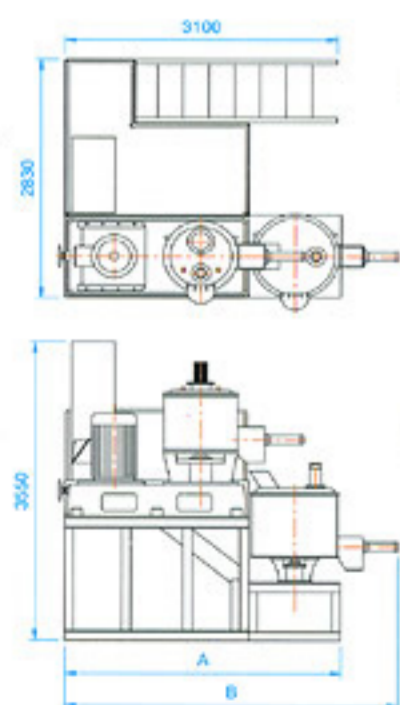

MODEL 機型	A	B	C
SM-HM200L SM-CB400L	3150	3790	2830
SM-HM300L SM-CB600L	3350	4005	2830
SM-HM500L SM-CB1000L	3600	4315	2880

HIGH-SPEED MIXER

高速熱混合機

- Adopts pole changeable 2 steps speed motor to drive for large volume material mixing, Also can use stepless, variable speed motor with inverter for different speed adjustment with different material characters.
本機可用二段速度變極馬達驅動, 適於量大之物料混合, 亦可用無段變速變頻馬達驅動, 可隨物料特性不同做不同速度之調整。

- The machine is mainly using for blending dry PVC with rigid or Thermoable poly plastics, ABS, PP, PE, Pigments,.....etc, are also applicable.
本機主要適用於乾式PVC混合攪拌硬質或可塑聚脂物料, 也適用ABS, PP, PE, 色母.....等。



MODEL 機型	SM-HM200L	SM-HM300L	SM-HM500L
Tank Capacity 桶容量	200L	300L	500L
Blending Capacity 攪拌容量	35~40kg	70~85kg	116~140kg
Power 馬力	60HP	100HP	150HP
Blending Cycle per hour 每小時攪拌次數	7~10	7~10	7~10
Machine weight 機械重量	1900kg	2130kg	2850kg

MODEL 機型	A	B	C	D	E
SM-HM200L	700	700	2870	1935	600
SM-HM300L	830	830	2930	1935	600
SM-HM500L	980	980	3005	1955	600

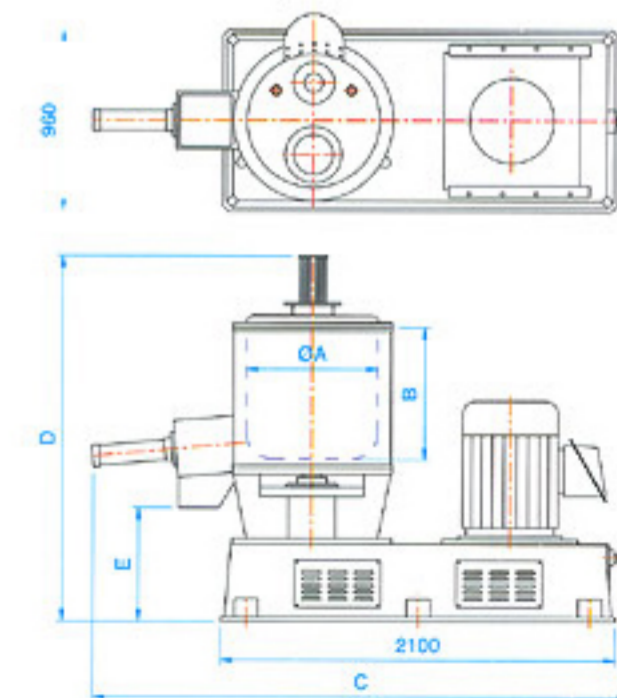

VERTICAL COOLING BLENDER

立式冷卻攪拌機

- The barrel is made of double stainless steel jacket. The internal space is with spiral blades for cooling water circulation, to effect heat dissipation.
本機的桶身是由雙層不銹鋼所構成, 桶壁中間拉旋轉葉片使冷卻水循環達到散熱效果。



MODEL 機型	SM-CB400	SM-CB600	SM-CB1000
Tank Capacity 桶容量	400L	600L	1000L
Blending Capacity 攪拌容量	35~40kg	70~85kg	116~140kg
Power 馬力	10HP	15HP	25HP
Blending Cycle per hour 每小時攪拌次數	7~10	7~10	7~10
Machine weight 機械重量	530kg	650kg	820kg

MODEL 機型	A	B	C	D	E	F	G
SM-CB400L	900	700	1050	2130	980	1230	840
SM-CB600L	1080	690	1250	2195	980	1430	915
SM-CB1000L	1400	700	1500	2195	1080	1600	915

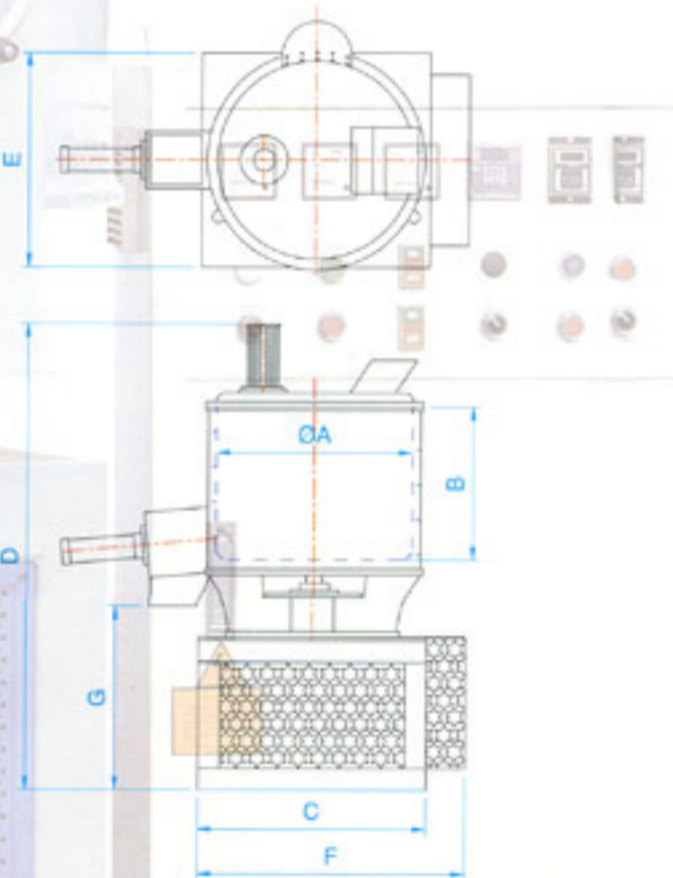

COOLING MINI BLENDER

立式冷卻攪拌機之小型試驗機

- Specially designed model for R&D department and experiment, Through the processing, the material wastes can be reduced.
開發部, 試驗室的試驗機, 作業時減少物料損失。



MODEL 機型	SM-CB75L	SM-CB100L
Tank Capacity 桶容量	75L	100L
Blending Capacity 攪拌容量	15kg	25kg
Power 馬力	5HP	10HP
Blending Cycle per hour 每小時攪拌次數	7~10	7~10
Machine weight 機械重量	300kg	400kg

MODEL 機型	A	B	C	D	E	F	G
SM-CB75L	460	500	1270	580	1452	600	650
SM-CB100L	600	380	1600	750	1652	720	1100

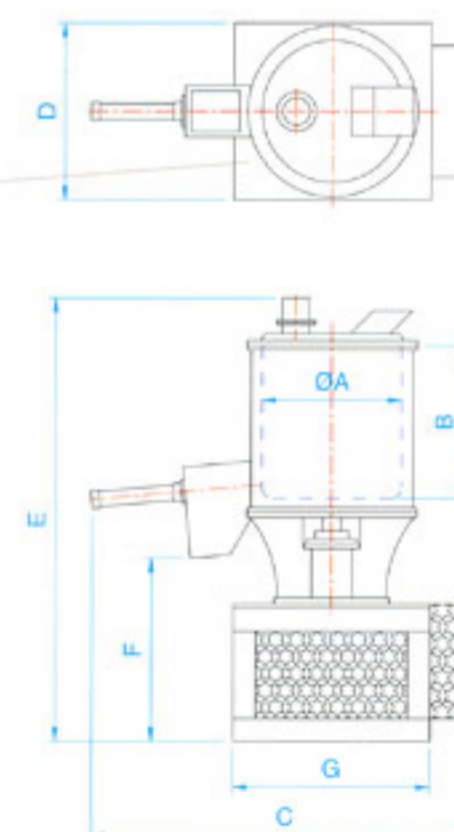

HIGH-SPEED MINI MIXER

高速混合試驗機



- Specially designed model for R&D department and experiment, Through the processing the material wastes can be reduced.
開發部, 試驗室的試驗機, 作業時減少物料損失。

- Numerous configurations and profiles available for different mixing requirements.
依不同的物料使用不同之攪拌葉片, 葉片尺寸隨桶身尺寸而變化。

- Blending blades are made of stainless steel SUS304 and are treated with gas flame for strong wear-resistance.
攪拌葉片是由不鏽鋼鑄造而成, 在易磨損部位加以噴焊處理而具耐磨特性。



MODEL 機型	SM-HM35L	SM-HM75L
Tank Capacity 桶容量	35L	75L
Blending Capacity 攪拌容量	7kg	14kg
Power 馬力	10HP	15HP
Blending Cycle per hour 每小時攪拌次數	7~10	7~10
Machine weight 機械重量	150kg	200kg

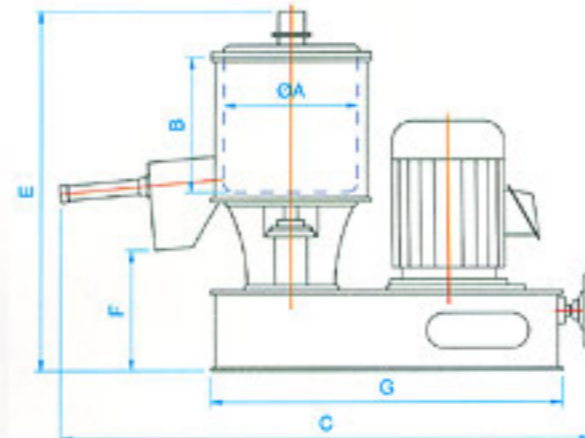
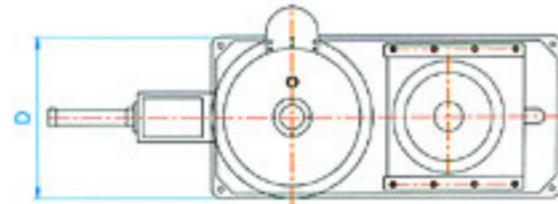

MODEL 機型	A	B	C	D	E	F	G
SM-HM35L	360	390	1665	500	1160	410	1100
SM-HM75L	460	460	1820	550	1225	4100	1200



HIGH-SPEED MIXER

高速熱三軸混合機

- The mixer fitted with high-speed motor and sturdy blending blades, the blades can crash the block material to be mixed homogeneously. It can mix various polymer materials perfectly. The heating distribution of our system is quite even, which will not destroy the materials property.

本機可混合多種物料並加裝桶邊的高轉速馬達及打散物料刀具，能使物料在短時間內將塊狀物料加速分散均勻混合，不積熱更不會破壞原物料品質。



BLENDING TANK

DRYING & COOLING BLENDER

臥式攪拌、乾燥及冷卻機

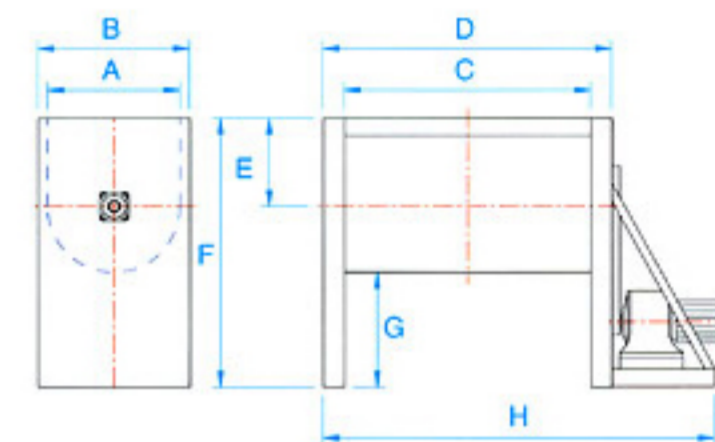
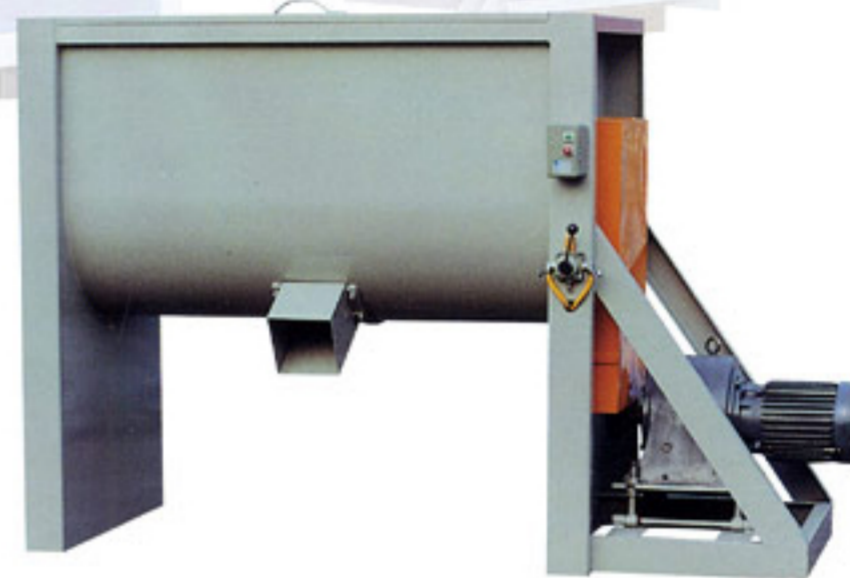

MODEL 機型	A	B	C	D	E	F	G	H	主軸	馬達	板厚	內容量
SM-D300	700	810	1200	1500	500	1525	675	2080	50	3HP	4.0	650L
SM-D400	750	860	1400	1640	500	1525	650	2230	55	5HP	4.5	834L
SM-D500	800	910	1500	1850	550	1650	700	2440	60	5HP	5.0	1037L
SM-D600	900	1012	1500	1850	600	1750	700	2690	65	7.5HP	6.0	1287L
SM-D800	1000	1113	1540	1910	650	1850	700	2900	70	10HP	6.0	1600L

HIGH-SPEED MIXER & BLENDING TANK

高速熱混合機 & 臥式攪拌桶

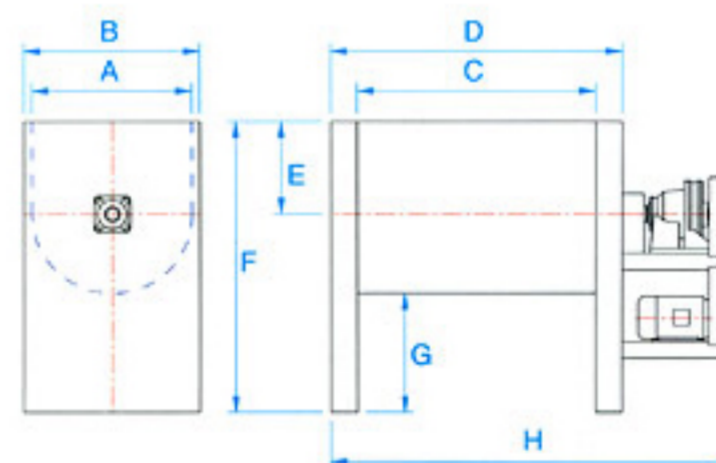

MODEL 機型	A	B	C	D	E	F	G	H	主軸	馬達	板厚	內容量
SM-D1000	1200	1320	1800	2200	700	2200	900	3058	75	15HP	8.0	2530L
SM-D1500	1300	1450	2000	2400	800	2350	900	3418	85	20HP	8.5	3407L
SM-D2000	1500	1650	2100	2500	900	2550	900	3568	100	20HP	8.0	4690L
SM-D3000	1800	1970	2440	2940	1000	2800	900	4210	120	25HP	10.0	7500L
SM-D5000	2000	2170	3550	3550	1200	3100	900	5125	130	30HP	10.0	12110L



Song Ming

Song Ming Machinery Ind., Ltd.

TEL: +886-4-26302115 FAX +886-4-26398162

URL: <http://www.songming.com.tw>

E-mail: sonmin@ms16.hinet.net

崧明機械工業有限公司

台中縣龍井鄉中和村工業路182號15弄5號

TEL: +886-4-26398161

FAX: +886-4-26398162

